

# Product Specification

**Brigade Model Number:** VBV-110C

**Brigade Stock Code:** A1852

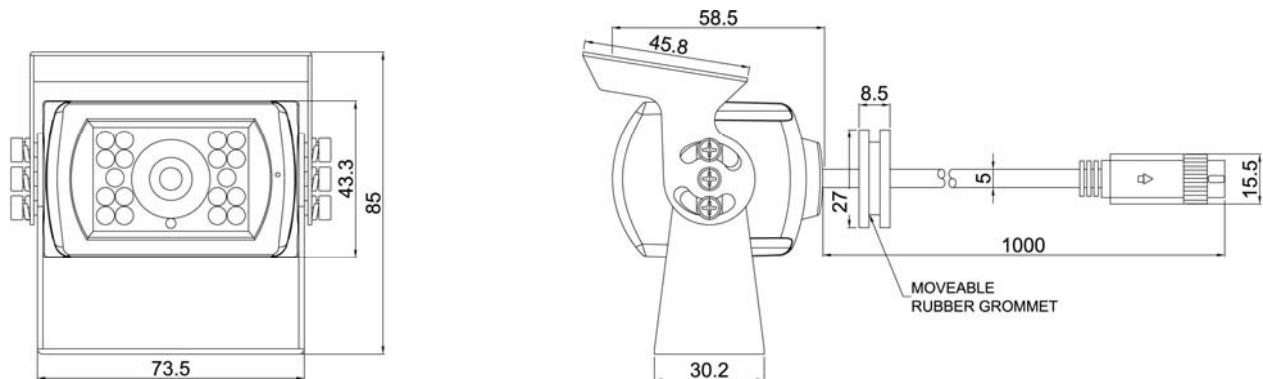

Dimensions: mm

## Product Specification

### Environmental Specifications:

- Shock Rating: 100 G
- Vibration Rating: 10 G
- Camera IP Rating: IP67
- Connector IP Rating: IP66
- Operating Temperature: -20° to +70°C
- Storage Temperature: -30° to +80°C

### Approved Standards:

- CE
- 2006/28/EC
- 2003/97/EC with compliant monitor.
- R46 with compliant monitor.
- 95/54/EC
- ECE R10.02
- HALT
- ISO 20653: 2006 (IP Testing)

### Technical Specifications:

- Operating Voltage: 12 Vdc
- Current Consumption: ≤300mA
- Power Consumption: ≤3.6 Watts
- Imaging Devices: CCD - 1/3" Sharp  
DSP - Sharp
- TV System: CCIR
- Picture Elements: 512 (H) x 582 (V)
- Visual Resolution: 420 TV Lines
- Lens Focal Length: 2.8mm
- Signal to Noise Ratio: >48dB
- Required Illumination: 0 Lux (IR LED ON)
- Illumination Distance: 15 Meters

### Technical Specifications Continued...

- Viewing Angle: 98° (H), 75° (V), 120° (D)
- Weight: 320 Grams
- Video Output: 1.0 Vp-p / 75Ω
- Length of Cable: 1 Meter
- Overall Dimensions: 88mm (W) x 66mm (D) x 85mm (H)
- Casing Material: Die cast Aluminium
- View: Mirror
- Finish: Black Power Coating

### Features:

- Back Light Compensation
- Automatic White Balance
- Automatic IRIS
- 18 x High Power Infrared LEDS
- Integrated Microphone
- VBV Type Connector
- High Quality Sharp CCD & DSP

### Package Contents:

- 1x Camera
- 1x Bracket
- 1x Sunshield
- 6x Screws